

Title		
Блок питания низковольтный		
Size	Document Number	Rev
A	<Doc>	<RevCode>
Date:	Saturday, February 24, 2018	Sheet 1 of 3

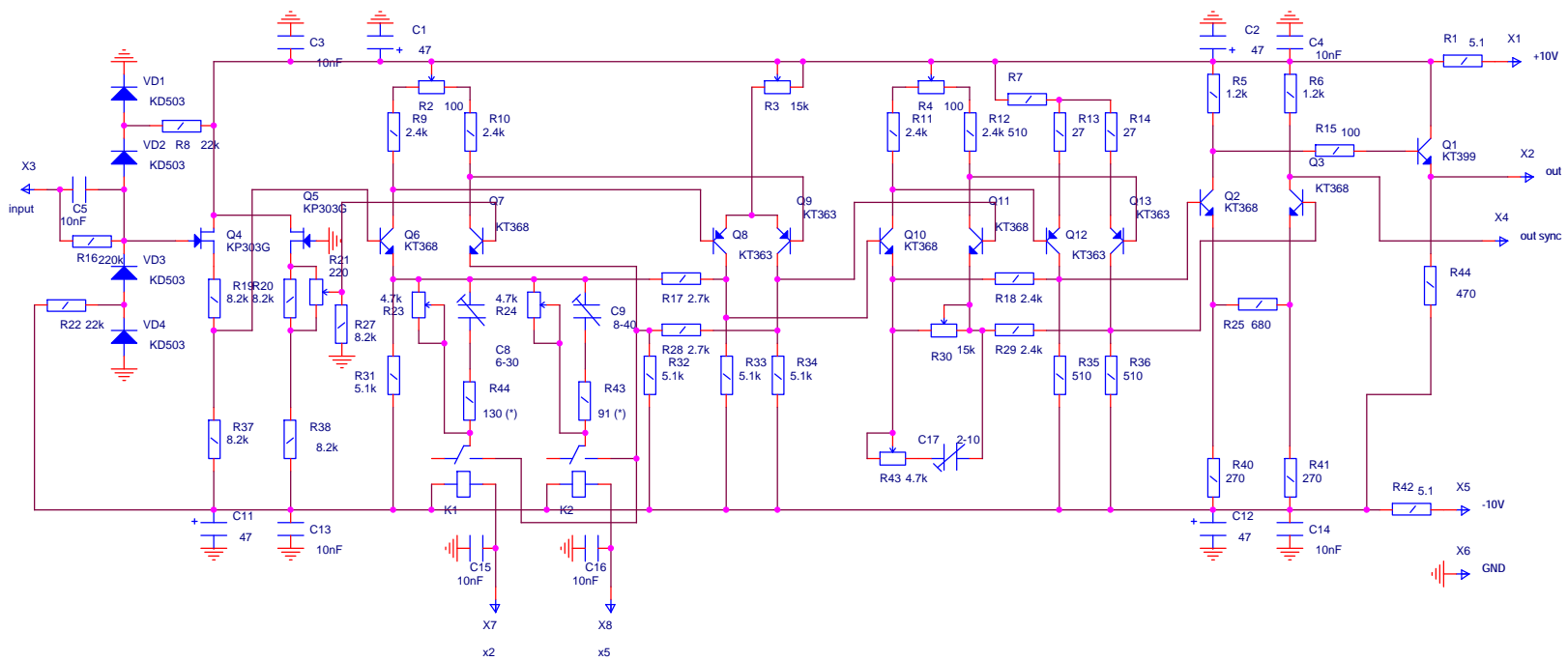

Title		
Предварительный усилитель У		
Size	Document Number	Rev
A3	<Doc>	<RevCode>
Date:	Monday, December 31, 2018	Sheet 1 of 2

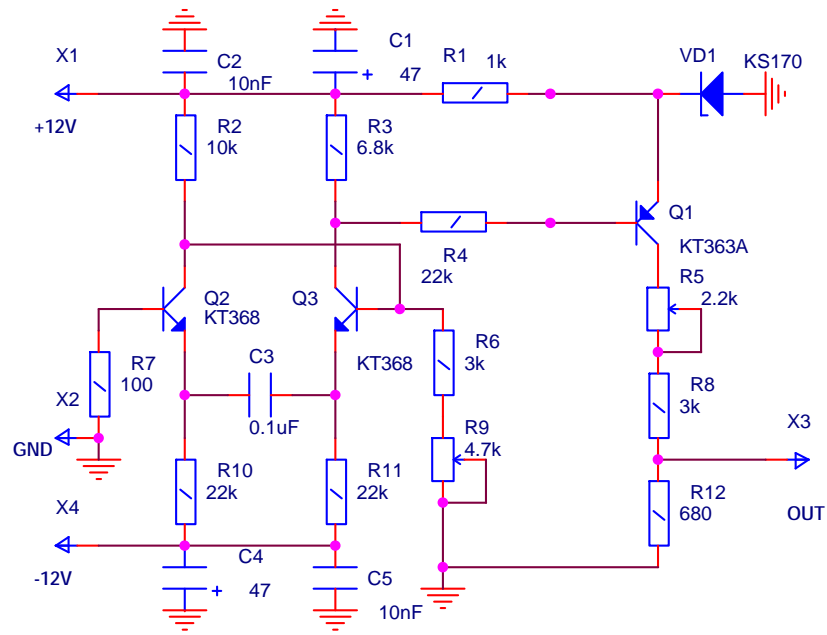

Title		
Калибратор		
Size	Document Number	Rev
A	<Док>	<RevCode>
Date:	Friday, September 14, 2018	Sheet 1 of 8

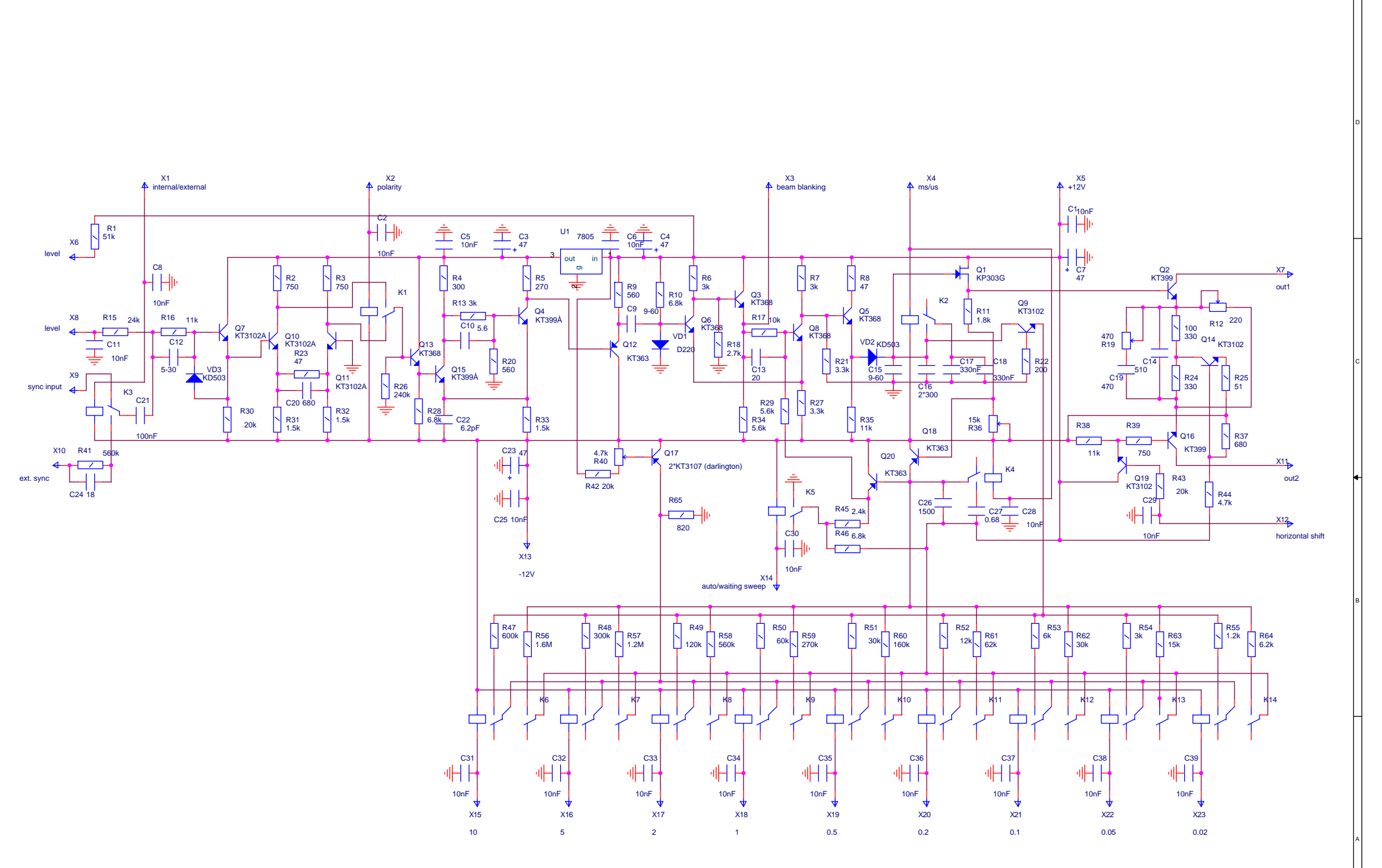

Title		Генератор развертки и схема синхронизации	
Size	A3	Document Number	<Doc>
Rev	<Rev>	Code	<Code>
Date:	Sunday, December 30, 2018	Sheet	1 of 4

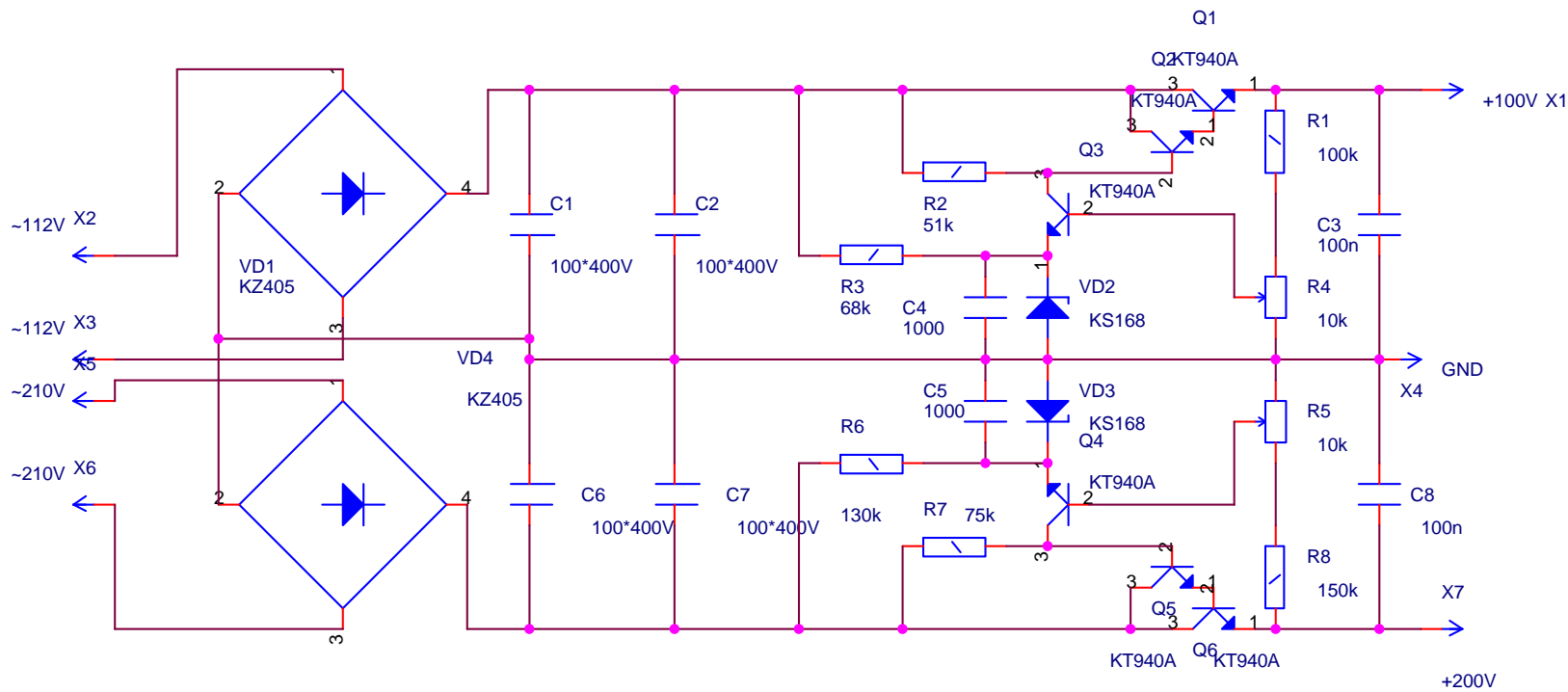

Title		
Блок питания оконечных каскадов		
Size	Document Number	Rev
A	<Doc>	<RevCode>
Date:	Saturday, February 24, 2018	Sheet 1 of 6

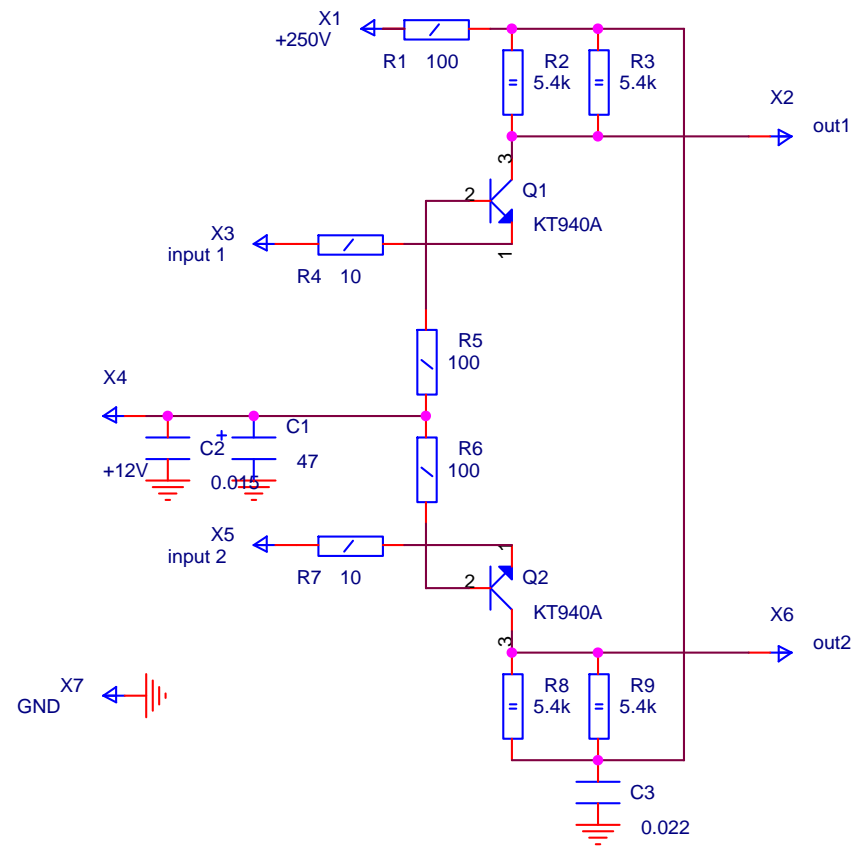

Title		
Оконечный усилитель X		
Size	Document Number	Rev
A	<Doc>	<RevCode>
Date:	Sunday, December 30, 2018	Sheet 1 of 5

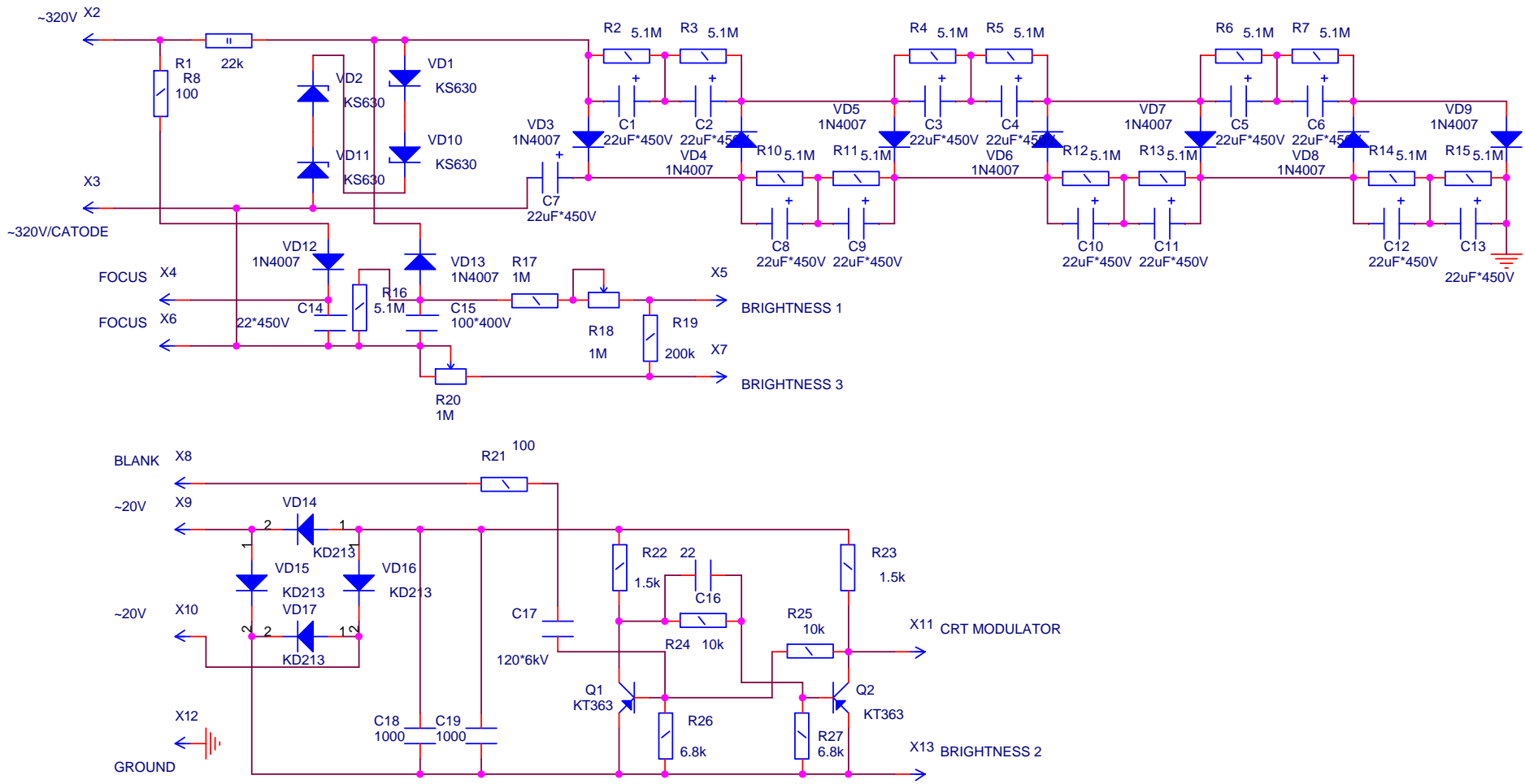

Title		Узел питания ЭЛТ	
Size	A4	Document Number	<Doc>
Date:	Sunday, December 30, 2018	Sheet	1 of 8
		Rev	<RevCode>

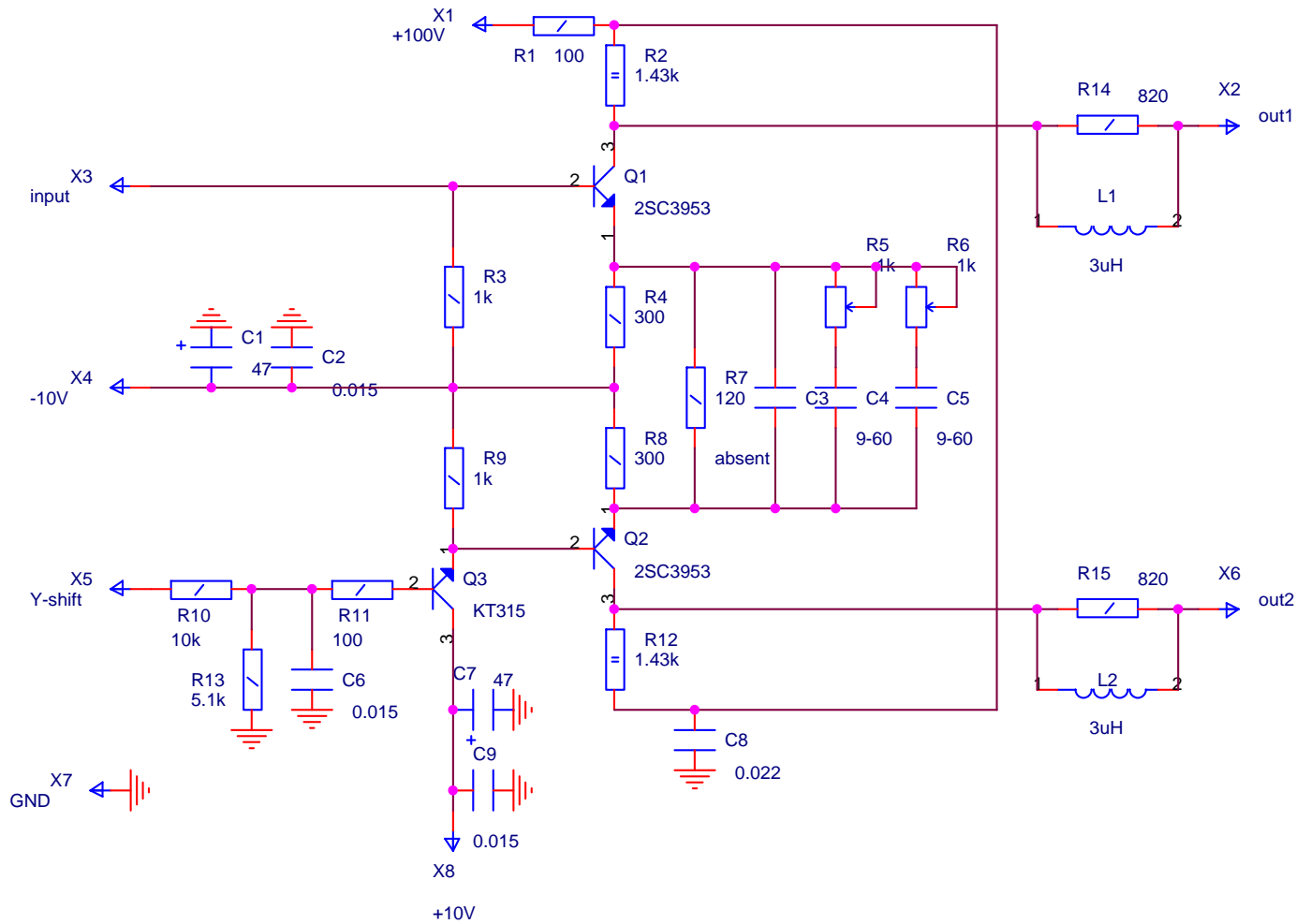

Title		
Оконечный усилитель КВО		
Size	Document Number	Rev
A	<Doc>	<RevCode>
Date:	Sunday, December 30, 2018	Sheet 1 of 5