

Title		
Блок питания низковольтный		
Size	Document Number	Rev
A	<Doc>	<RevCode>
Date:	Saturday, February 24, 2018	Sheet 1 of 3

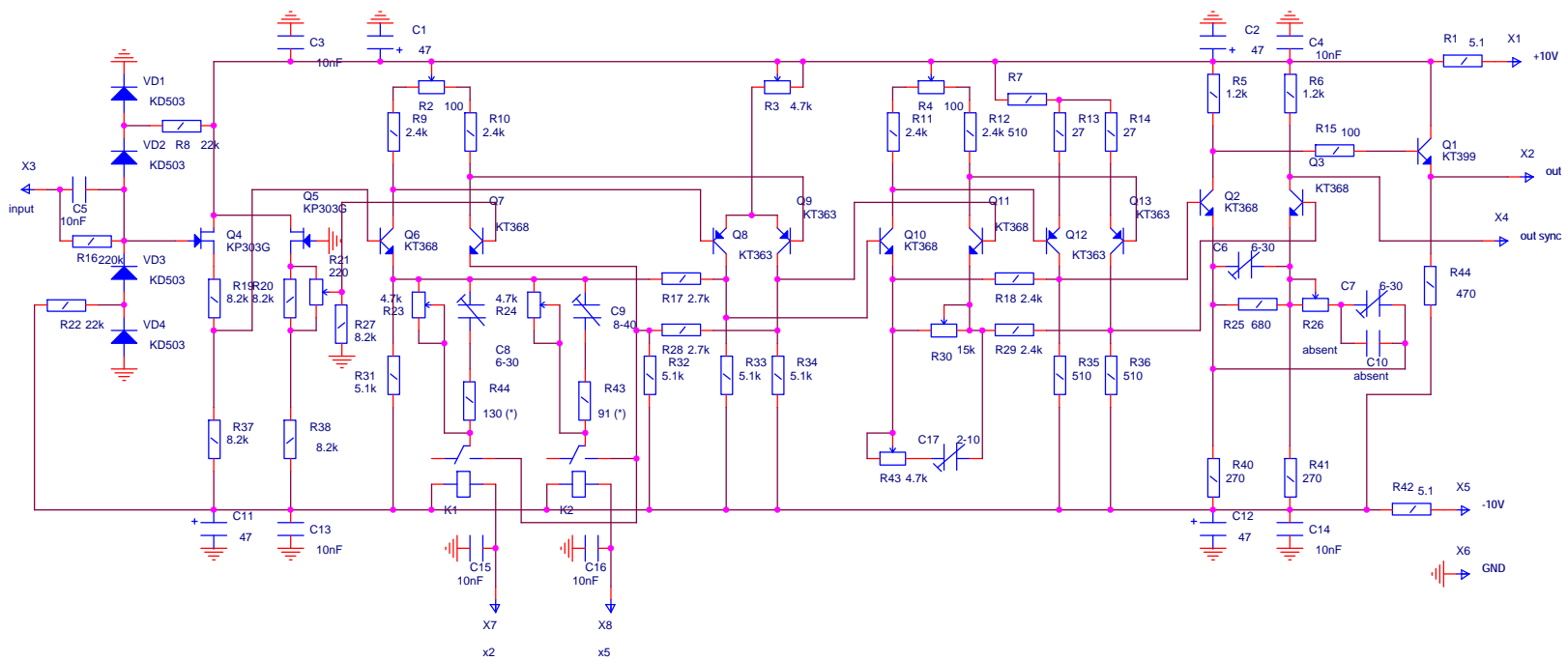

Title		
Предварительный усилитель У		
Size	Document Number	Rev
A3	<Doc>	<RevCode>
Date:	Saturday, February 24, 2018	Sheet 1 of 2

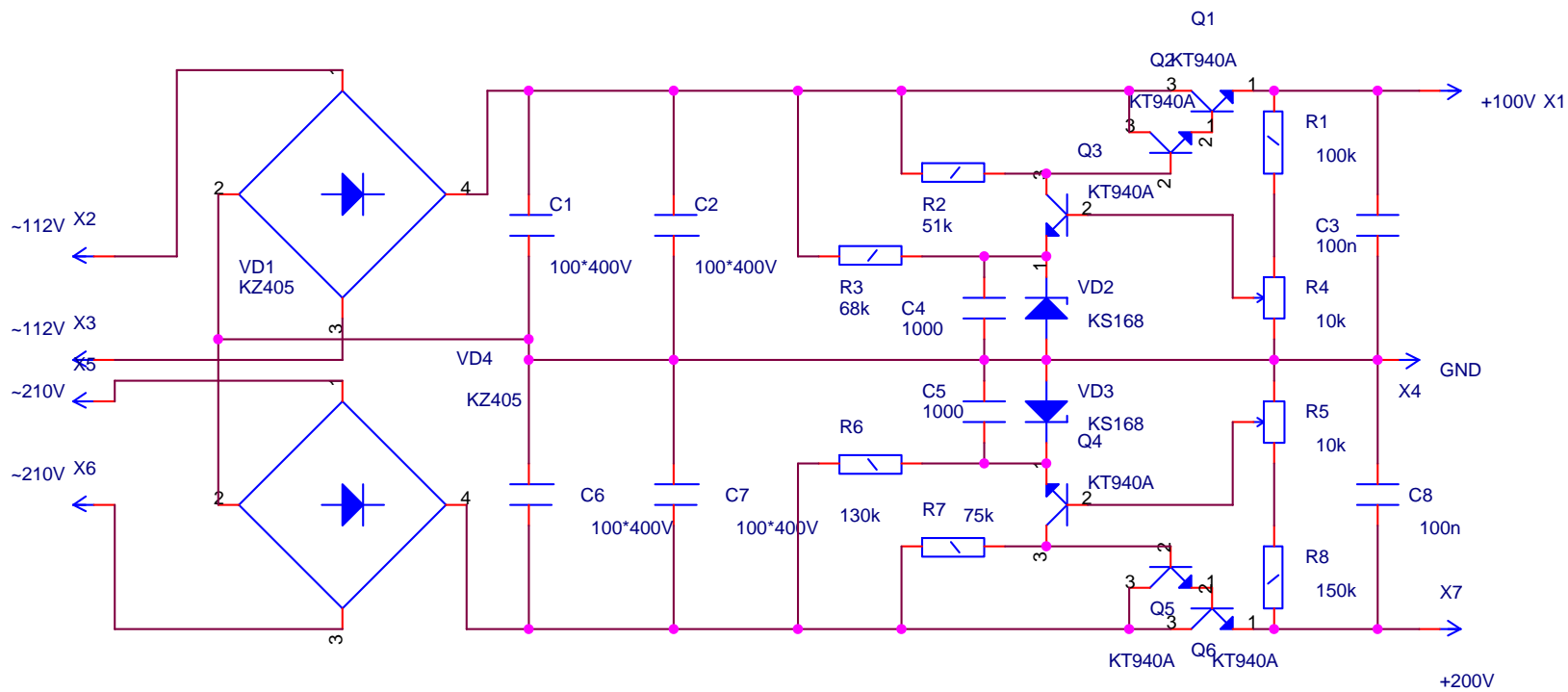

Title		
Блок питания оконечных каскадов		
Size	Document Number	Rev
A	<Doc>	<RevCode>
Date:	Saturday, February 24, 2018	Sheet 1 of 6

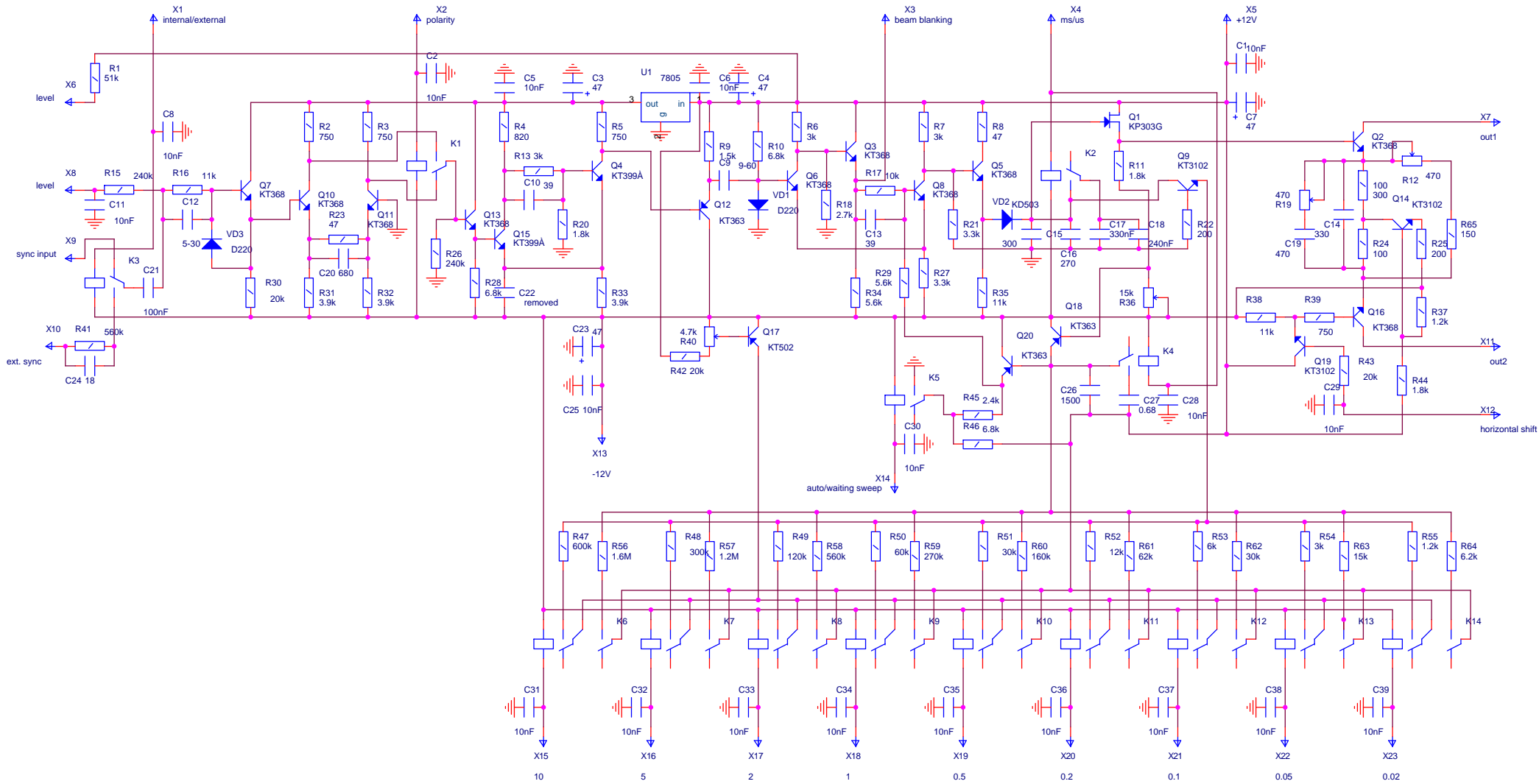

Title		
Генератор развертки и схема синхронизации		
Size	Document Number	Rev
A3	<Doc>	<RevCode>
Date:	Saturday, February 24, 2018	Sheet 1 of 4

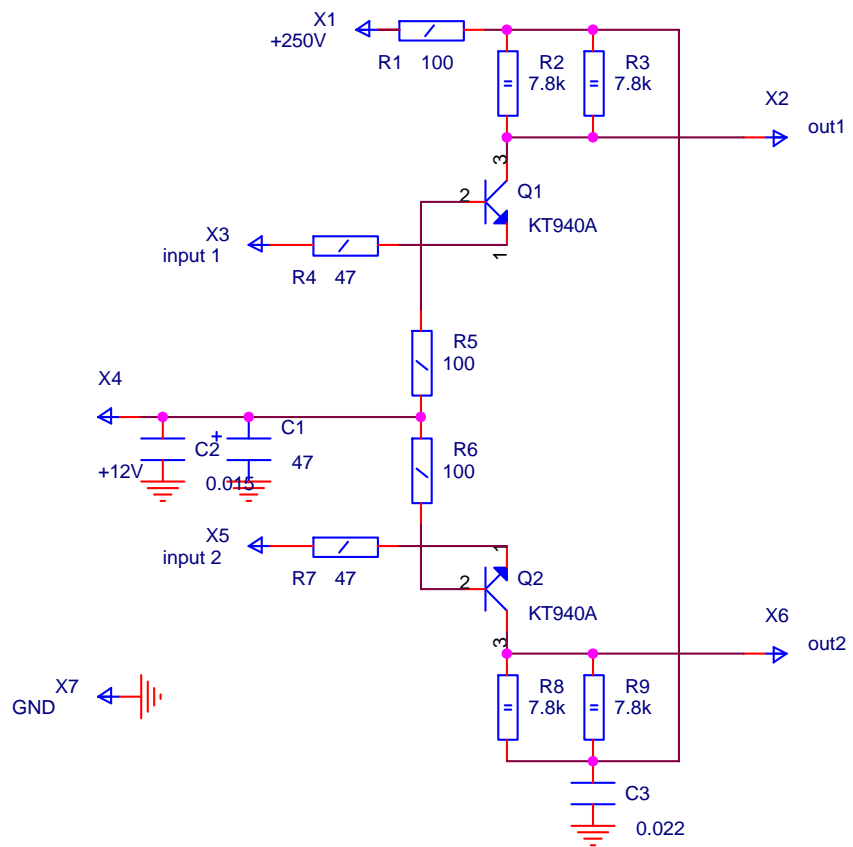

Title		
Оконечный усилитель X		
Size	Document Number	Rev
A	<Doc>	<RevCode>
Date:	Saturday, February 24, 2018	Sheet 1 of 5

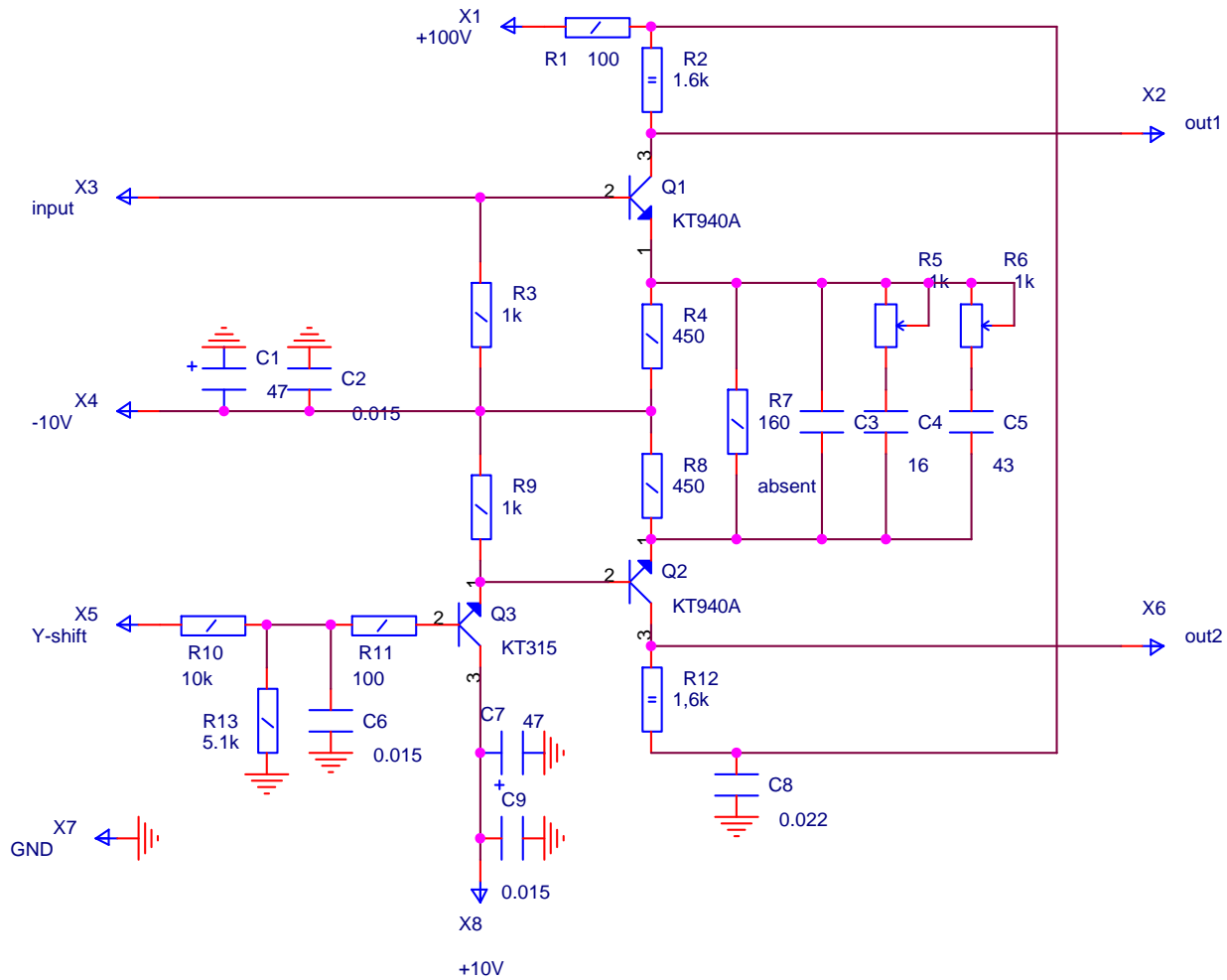

Title		
Оконечный усилитель КВО		
Size	Document Number	Rev
A	<Doc>	<RevCode>
Date:	Sunday, February 11, 2018	Sheet 1 of 5

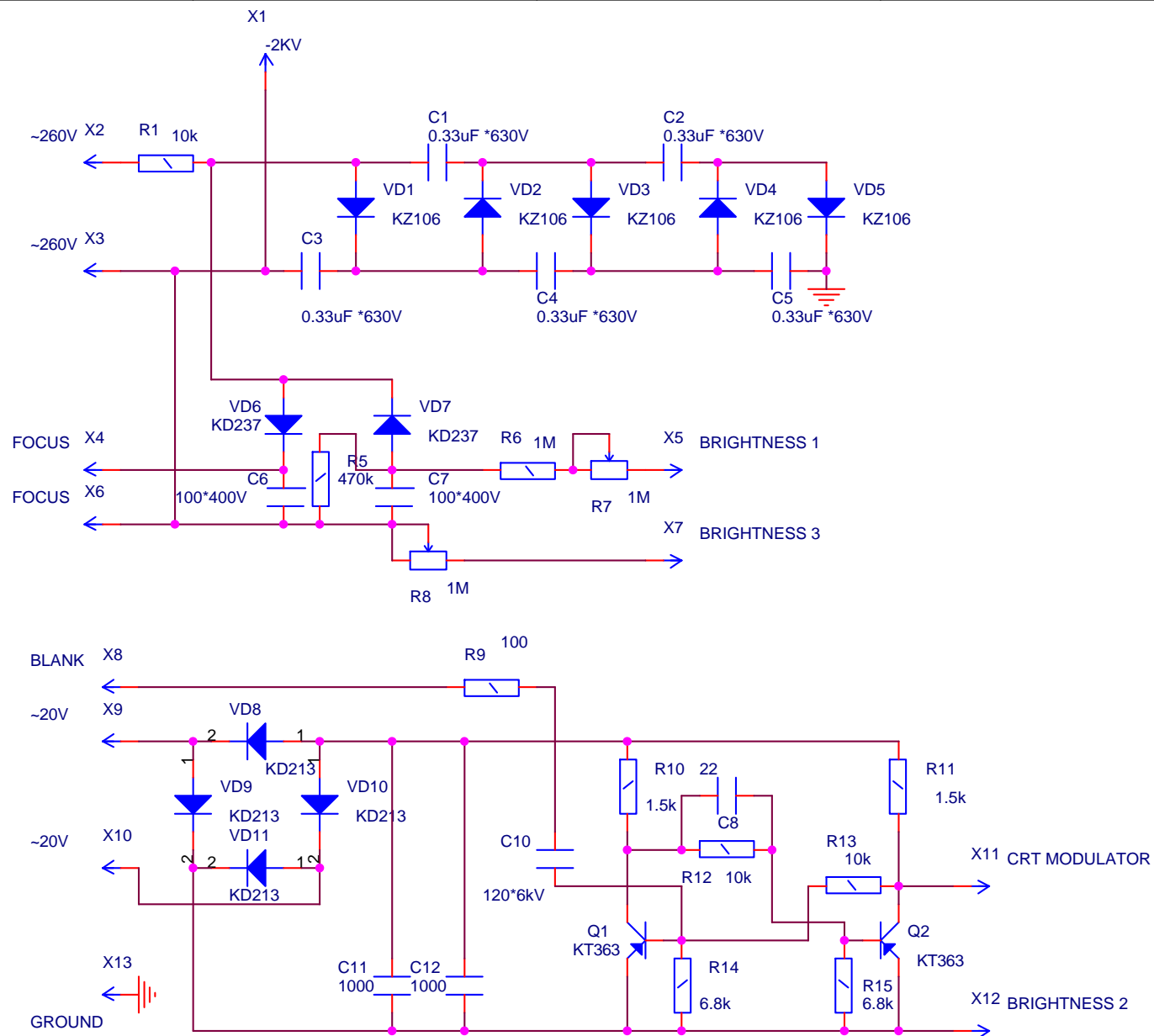

Title		
Узел питания ЭЛТ		
Size	Document Number	Rev
A	<Док>	<RevCode>
Date:	Saturday, February 24, 2018	Sheet 1 of 7